

General Information on the Design of Collars and Pilots for SpringGuard Telescopic Springs

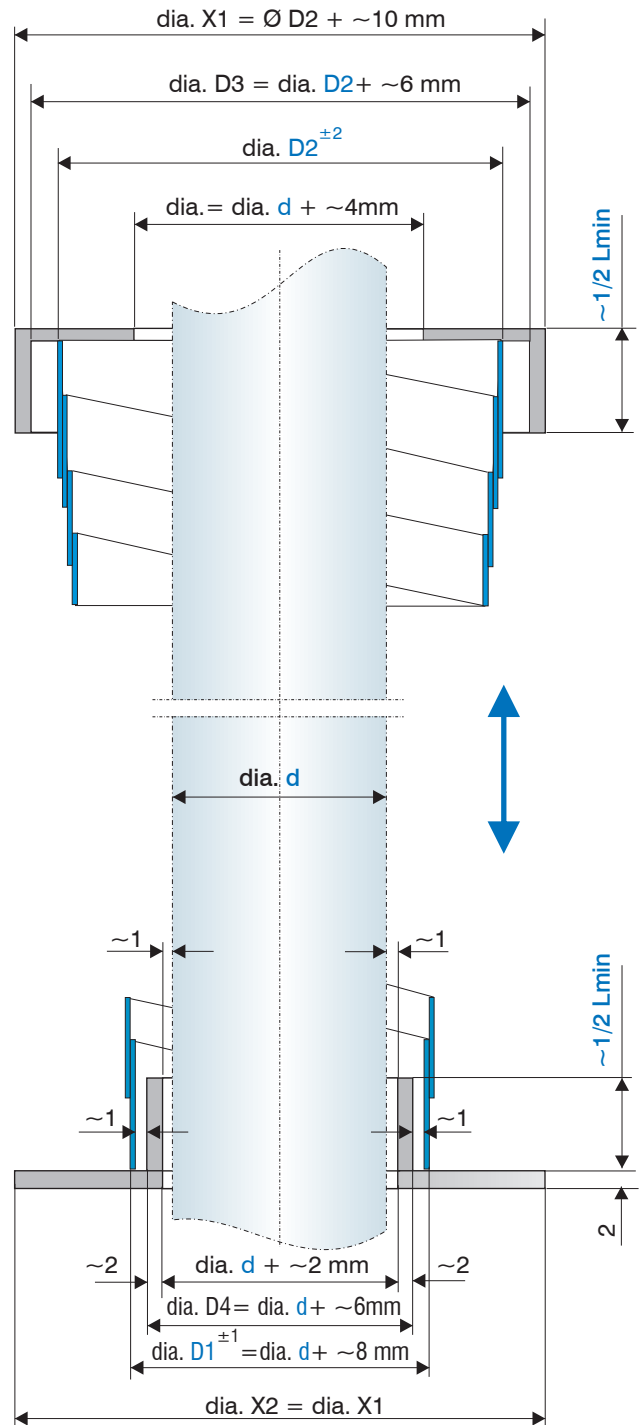

SpringGuard Telescopic Springs are very easy to mount. A collar on one side and a pilot on the other are entirely sufficient. The springs must be able to move freely in them. They must not be fixed.

If you wish to use a pilot and a collar, you should make allowance for the space needed. In other words, the inside diameter of the spring (D1) should in this case be chosen slightly larger, to make sure that the spring will fit over the pilot.

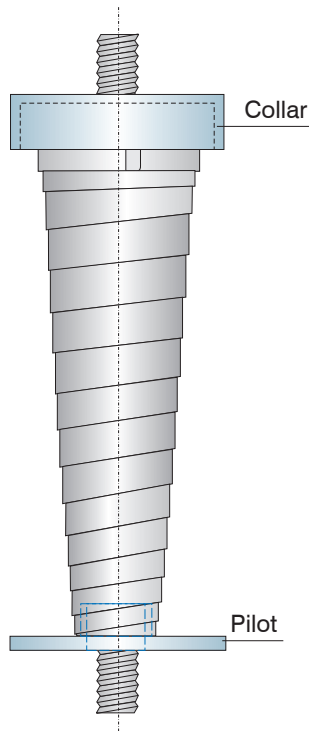

Example:

You would like to protect a spindle with a diameter of 11 mm with the aid of a telescopic spring with pilot and collar. Allow 2x approx. 1 mm play for the pilot opening and 2x 2 mm for pilot thickness. The outside dimension of pilot D4 thus are 17 mm. To this you add another 2x approx. 1 mm for play between the pilot and the inside diameter of the spring. Result: D1 = 19 mm. Then, choose the next larger dimension D1 from the table in our catalog TF 03 (in this case, D1 would be 20 mm). There you find the spring you want.

Table of dimensions of collars for telescopic springs (example)

